

Thank you for selecting CONTRACTOR SOLUTIONS. To ensure that your installation proceeds smoothly, please read these instructions carefully before you begin.

Unpack the sink carefully and check all parts.

1. Use the cardboard template provided to cut the hole (RECOMMENDED) Put the template on the counter top, and make sure it is parallel to the front of the counter top. Trace the cutting line (Fig. 1)

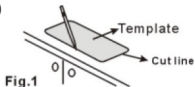

If you do not have the cardboard template, place the sink upside down on the counter top and make sure it is parallel to the front of the counter top. Trace the outline (Fig. 2) Then draw a new line 3/8 inches (10 mm) inside the outline. This will be the cut line (Fig. 3) The size of the cut line should be 76.8 cm x 50.1 cm (30-1/4" x 19-3/4").

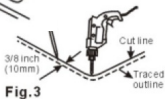
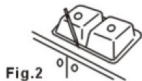

2. Carefully drill a hole inside the cut line and use a saber-saw or jig-saw to start cutting along the cut line. Place a support underneath the cutout portion of the countertop to prevent it from falling during cutting (Fig. 4)

**Fig. 4**

3. Test the whole assembly to see if it fits properly. Adjust cut-out if necessary. (Fig. 5)

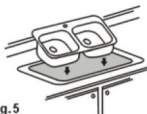
**Fig. 5**

4. Apply silicone sealant around the underside of sink rim (Fig. 6)

**Fig. 6**

5. Carefully put sink right side up and insert bolts in notches, putting clamps flat against the sink. Swing the clamps. Tighten the screws progressively on Fig. 8 until the sink rim is flush with countertop. Check the alignment as you tighten so that the front of the sink is parallel to the front of the counter top. Check all connections for leaks. Adjust and re-tighten if necessary. Do NOT overtighten (Fig. 7)

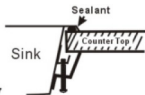
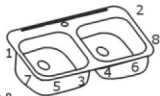
**Fig. 7****Fig. 8**

Strainer Installation

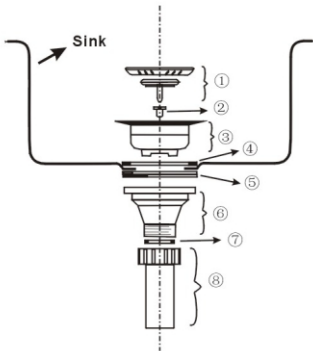

- ① Basket
- ② Locknut
- ③ Strainer upper body
- ④ Thin rubber gasket
- ⑤ Thick rubber gasket
- ⑥ Strainer lower body
- ⑦ Small rubber gasket
- ⑧ Tail